

ULTRASONIC FLOW MEASUREMENT FOR UNIT TESTING AND PERFORMANCE MONITORING AT LOW-HEAD HYDROELECTRIC PLANTS

**Terrance L. Burch and James T. Walsh
Accusonic Technologies, Inc.**

1. Introduction: The Need for High-Accuracy Flow Measurement

Testing and evaluation of turbine-generator performance at hydroelectric plants has always depended critically on the availability of precision flow (unit discharge) measurements. Flowrate, head, and electrical power output are key parameters that must be known in relation to each other for determining actual unit power output vs. discharge and efficiency characteristics for individual units as well as for total plant outputs.

A variety of flow measurement techniques have been developed and refined for hydro applications over the course of this century, including both absolute and relative methods to quantify unit discharge. These have been used for unit acceptance tests, operational enhancement, evaluation of unit upgrades, and plant refurbishment planning. Characterizing real unit performance provides necessary information needed for these purposes, and serves to justify new capital investments as well as improving the specification of rehabilitated equipment.

Precision has been a requirement in unit performance measurement in order to obtain repeatable results, consistent (at least) within individual unit test programs. High-accuracy unit flow data, providing both high precision plus low bias error, have typically been required to document absolute unit efficiency in meeting contractual acceptance criteria for new or upgraded units. Further requirements for high-accuracy flow and absolute unit efficiency data have steadily grown in recent decades in response to needs for maximizing powerplant output and efficient use of water resources.

Flow measurement methods that have been widely utilized for unit field testing and performance evaluation include the pressure-time technique, salt velocity method, dye-dilution method, area-velocity (current-meter array) measurements, and the ultrasonic transit-time method (Gulliver and Arndt, Ref. 1.). Most of these applications have been at hydroplants having penstocks or other long flow conveyance structures providing well-developed, relatively uniform hydraulic flow profiles. Such circumstances are also a good representation of turbine model test conditions and improve the realization of model-to-prototype performance predictions.

These techniques have been distilled into the strictly prescribed methods given in the relevant turbine test codes utilized by the American Society of Mechanical Engineers (ASME, Ref. 2.) and the International Electrotechnical Commission (IEC, Ref. 3.). Performance guarantees offered by turbine manufacturers are typically validated using one of these code-accepted flow measurement methods.

Methods for obtaining accurate flow measurements at low-head hydroelectric facilities are much more constrained due to the short reach available between water intake and turbine inlet. Typical low-head plant configurations utilize multiple intake bays for each turbine inlet with short, irregular geometry giving rise to non-uniform, variable flow conditions that are not well-suited in general to the code-prescribed methods. Further flow variability can arise from effects induced by the operation of adjacent units which can make it difficult to determine unit flow vs. gate setting relationships.

Since a considerable number of the world's large hydroelectric power plants are included in the low-head category, it is important to investigate and develop new or modified methods for obtaining reasonably accurate flow measurements under these conditions. This will lead to more meaningful hydroelectric performance evaluations that are needed for optimization of plant operation and management of constrained water resources. Critical decision making in the allocation of capital resources to achieve greater power generation efficiency can also be enhanced with better unit performance assessment - the question of whether to upgrade or refurbish may be more easily decided with realistic data for existing units in hand. This information is not readily derivable from model turbine tests or numerical computer simulations. Accurate unit flow and efficiency measurements under actual field conditions is the key.

2. Low-Head Unit Flow Measurement Methods

The difficult, non-uniform hydraulic conditions in low-head plant intakes prevent the straightforward application of traditional flow measurement techniques developed for use in well-conditioned, long-penstock flow regimes. Short, convergent intake structures introduce swirl, cross-axial flow components, and significant distortions in the vertical and horizontal flow velocity profiles. Large turbulent eddies, flow separation, and potential backflow phenomena may be present, with conditions further confounded by the presence of trash racks, fish diversion screens, or other protruding structures. This leads, as well, to much less conformity in plant-to-plant flow characteristics, so that techniques developed and experience garnered at any particular facility will not usually be directly applicable at some other low-head plant without careful consideration of potentially unique conditions and appropriate modifications to flow measurement procedures.

Because of such factors, unit flowrate measurement accuracy and repeatability that is achievable in low-head intakes is at best 2 to 3 times less than for flows measured in penstocks. Until recently, techniques used for absolute flowrate and efficiency measurements at low-head plants have nearly all been based on the area-velocity method, comprising either fixed-in-place or intake-traversing current-meter arrays. Propeller-type current meters, as specified by the relevant codes for penstock-based unit testing, have generally been used in unit field test programs; however, there have been cases using other types of water velocity sensors (e.g., see Voight and Gulliver, Ref. 4.).

The number of current-meters (i.e., point-velocity samples) needed in low-head intakes is generally 2 or 3 times that required for penstock measurements (Levesque, Ref. 5.). Thus, the measurement apparatus itself may cause significant flow interference, adding to the uncertainty for measured flow vs. unit gate setting. In addition, traversing current-meter arrays that are moved to different positions across the intake flow profile depend on stable, steady-state flow conditions during a complete intake measurement cycle.

Relative flow measurements, based on the differential pressure between taps located on the turbine scroll case (i.e., Winter-Kennedy taps) or in a converging turbine inlet, can be used for unit index testing. For these cases, no absolute measurement of unit flow is obtained, and performance test data is indexed to the unit's peak efficiency setting. While index testing provides the shape of a unit's efficiency curve and the gate setting for peak efficiency, it does not define absolute unit efficiency (power output vs. actual unit cfs discharge) nor can it be used for determining actual unit-to-unit differences in power output efficiency (Voight and Gulliver, Ref. 4.). As with the absolute flowrate techniques discussed above, relative flow data obtained via such differential pressure measurements can also be adversely affected by irregular flow conditions in the unit intakes, resulting in decreased precision for unit index test results.

The multiple-path, ultrasonic transit-time method of flowrate measurement offers a means for obtaining meaningful unit flow and efficiency data under the variable hydraulic flow conditions found at low-head hydroelectric plants. Flow and efficiency measurements utilizing the multi-path ultrasonic transit-time technique at low-head plants have shown close agreement with results obtained via current-meter arrays deployed across multiple-bay intakes. This method is described in the following sections of this paper, along with summaries of results from an actual test site.

The close agreement between the two flowrate measurement methods and consistency in the test results demonstrate that the ultrasonic method represents a valuable tool for unit performance testing and evaluation at low-head hydropower plants. In addition to measuring absolute unit discharge for efficiency determination, the method provides detailed information on the character of intake flow velocity profiles, including the magnitude of cross-flow (non-axial) components, vertical flow profile variation across the intake, time-varying flow behavior, and bay-to-bay flow differences.

This kind of information can be useful for identifying performance-degrading intake flow conditions, designing appropriate modifications to forebay and intake structures, and evaluating possible improvements in plant operation.

A significant advantage associated with the ultrasonic method (for both low-head intakes and penstock unit flows) is that it is the only available absolute flow measurement technique that can be used for continuous on-line unit monitoring during normal powerplant operations. This provides a valuable capability for unit performance documentation and evaluation under widely varying total plant head and flow conditions, and for optimizing unit commitment and load dispatch to achieve maximum power generation efficiency at multi-unit hydroplants.

3. Flow Patterns and Ultrasonic Configurations in Low-Head Intakes

In low-head hydroplants with multiple-bay unit intakes, the velocity field typically varies from bay to bay. Figure 1 illustrates some fairly typical proportional flowrates found for a unit tested with a 3-bay intake, presented in a simple pie chart where the individual bay flowrates are shown relative to total unit discharge. Bay A, with 38 % of the unit's total flow, carries about 5% more of the total flow than would result from equal flow partitioning among the bays, and Bay C about 4 % less. Relative to each other, the flowrate through Bay A is 31 % greater than for Bay C.

The arrangement of the intake bays with respect to the turbine scroll case inlet is shown in the plan view of Figure 3. Flow through Bay A is seen to have more direct passage to the turbine inlet.

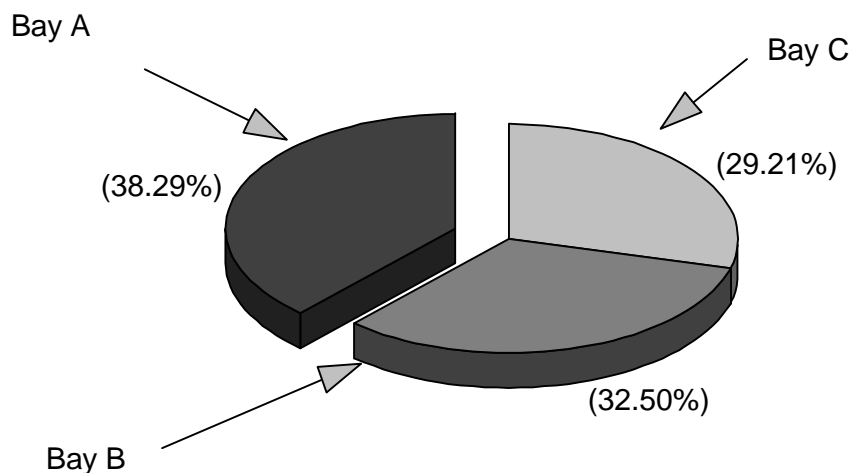

Figure 1. Flowrate distribution found in a 3-bay intake.

Intake flow distribution can change over time if debris is allowed to collect on forebay trashracks without regular cleaning . Other influences may include fish diversion screens that are installed during downstream migratory periods, as in the Pacific Northwest. During the winter season, ice forming on the trashracks can also significantly alter the flow distribution through the bays. In multi-unit low-head plants, the operation of adjacent units may have prominent effects on the overall flow distribution among intake bays, as well. This will likely change as the gate settings of units are varied to follow daily power generation demand or adjusted to changing river flow conditions.

All of these perturbations to intake flow distribution will also have concomitant effects on the characteristics of the 3-dimensional flow velocity field through the intake conduits. Highly non-uniform intake flow patterns may result from a combination of such factors and can affect not only the direct measurement of flow through the intake bays, but the operating performance of the turbine as well (Fisher and Franke, Ref. 6.). Such non-uniform intake flows can also adversely affect differential pressures measured at the turbine inlet or in the scroll case and lead to errors in the relative unit flowrates used for index testing (Nguyen, et.al., Ref. 7.).

Even with well-conditioned approach flows and good flow distribution among multiple intakes, non-uniform geometry of intake flow conduits can lead to non-axial flow velocities which complicate any flow measurement approach. Tapered forebay and intake entrances can create cross-axial velocity fields with large horizontal and/or vertical components and add to non-symmetrical behavior of the velocity field streamlines. Convergent sections will accelerate and change the direction of the flow velocity vectors as a 3-dimensional function of position along the conduit. Large eddies and flow separation arising from non-streamlined protrusions or obstructions can even result in regions of backflow within the intake flow velocity profile.

Velocity fields having significant non-axial flow components may result in significant errors when current meters are used to sample the flow profile. Arrays of propeller-type meters typically utilized (and code-specified) for flow measurement are not well-suited for accurately resolving axial flow in the presence of large off-axis components, and without special precautions may indicate forward velocities in the presence of backflow!

With judicious selection of acoustic-path placement and utilization of crossed-plane path arrays, the multiple-path ultrasonic transit-time method can be used to maintain reasonable accuracy and repeatability for continuous flowrate measurement under many of these difficult hydraulic conditions. Since acoustic transit-time measurement provides a spatial average of flow velocity along the entire length of an acoustic path, multiple paths spanning the entire breadth of a flow conduit may be utilized to sample average velocities at various levels across the flow profile. The measured path velocities are numerically integrated, taking into account corresponding flow areas, to provide an estimate of the flowrate through a complete bay cross-section. Total unit flow is then determined by the flowmeter via summing of the flow through each contributing bay.

Acoustic paths arranged in crossed-plane configurations may be effectively used to monitor and correct for the effects of cross-axial or swirling flow components. Velocity measurements from crossed-paths at a particular vertical level will feature an increased apparent velocity for the path more closely aligned with the non-axial velocity vector, and a decreased velocity for the crossing path. The two measurements may be combined to provide a much more accurate estimate of the average axial flow velocity at the level of the path. Much of the flowrate uncertainty caused by horizontal cross-flows or axially swirling flow can be eliminated in this manner. In addition, the crossed-path velocity measurements can be used to quantify the severity of cross-axial flows relative to the overall flow pattern. Thus, useful engineering information may be gained with respect to unit performance problems caused by poor intake hydraulics.

Applications where the intake is tapered along a convergent section, as shown in elevation view in Figure 2, pose a challenge to the installation of acoustic-path transducers. The use of articulated transducer assemblies allows for transducer alignment and positioning in such cases, and also permits mounting inside roughly lined intakes with no flat surfaces. The articulated-mount transducer design permits acoustic-path orientation to be parallel to the expected flow streamlines along the vault and eliminates the potential need to correct for vertical off-axis effects.

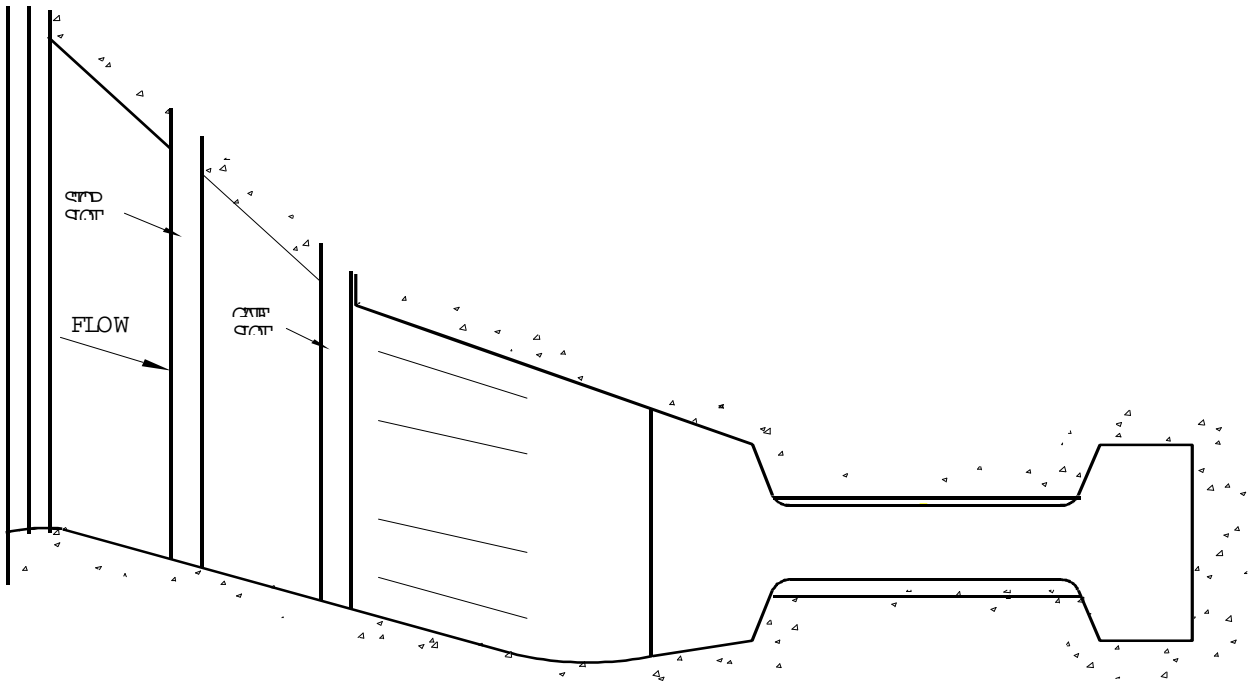

Figure 2. Acoustic-path placement in convergent intake requiring articulated transducers.

The number and placement of acoustic paths for intake flowrate measurement using the acoustic method is governed by the degree of non-uniformity present in the intake flow profile. For intake flow profiles having moderate variability, acoustic-path arrays comprising two crossed-planes of 4 paths each (termed a 4 x 4 path array) are used.

Vertical positioning for each pair of crossed paths in the intake flow conduit(s) is determined using “Gaussian” spacing. Weighting coefficients corresponding to these placements are then used in the numerical integration of path-velocities over the full intake flow profile. The Gaussian integration technique, which is a code-specified flow integration method (e.g., IEC, Ref. 3.), specifies the elevation and relative weighting of the acoustic paths for flowrate measurements in rectangular sections. This integration technique is well suited to flows with arbitrary (non-circular) cross section and is ideal for rectangular conduits.

Figure 3 illustrates the location, vertical spacing, and path numbering convention used for the acoustic paths installed in three 26-foot high, rectangular intake bays.

Intake flow profiles with greater cross-sectional variability may require configuring more acoustic paths than the 4 x 4 path arrangement to acquire additional samples across the flow profile and maintain flowrate accuracy.

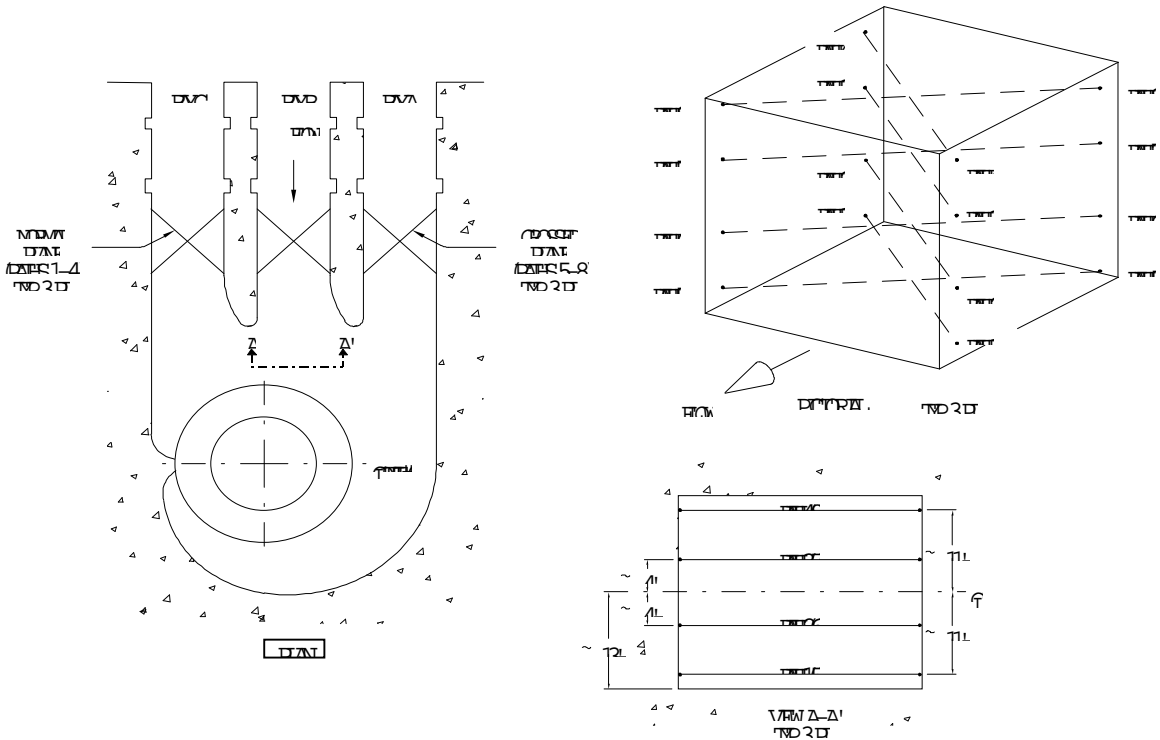

Figure 3. Ultrasonic flowmeter acoustic-path arrangement for a low-head 3-bay intake configuration.

Since the repeatability and linearity of flowrate measurements made with 4 x 4 path arrays can be quite good, even under moderately irregular flow profile conditions, it may only be necessary to configure one of the bays in a multi-bay unit intake with additional acoustic paths. The more highly resolved flow profile and enhanced flowrate accuracy resulting from the additional acoustic-path placements in such a “primary” bay, in some cases, may be used to calculate corrections for any systematic bias engendered by the 4 x 4 array sampling in the adjacent bays. Once so determined, the correction factors can be programmed into the flowmeter for automatic compensation in unit flow monitoring.

For intakes with highly irregular flow caused by the protrusion of non-streamlined obstructions into the flow or resulting from other major flow perturbations, additional acoustic paths will be needed in each bay to adequately sample and characterize the significant features in the cross-sectional flow profile. Such flow perturbations may be present only occasionally, under certain operating conditions (e.g., during the deployment of fish diversion screens). Thus, care must be exercised in the planning and arrangement of acoustic path arrays to take account of potentially intermittent flow profile disturbances.

4. Flowrate Intercomparison of the Ultrasonic Method vs. Current Meters

In October, 1993, flowrate measurements were performed using both the ultrasonic and current-meter methods at the Safe Harbor Water Power Corporation hydroelectric plant in Conestoga, Pennsylvania. This facility is located on the Susquehanna River, operating 12 turbine-generator units of Kaplan and mixed-flow type. Typical operating heads range from 51 to 58 ft. Simultaneous measurements were conducted with the two absolute flowrate methods in the 3-bay intake for Unit No. 6 (Kaplan) during unit field testing activities at the plant. The respective flow measurements were conducted independently by Accusonic and Alden Research Labs (ARL) for later intercomparison (Walsh, Ref. 8.).

Flow measurements were made simultaneously in all three intake bays over a sequence comprising 8 different unit wicket gate settings. A 4 x 4 acoustic-path array was installed in each 16-ft W x 26-ft H bay, with the acoustic path levels determined by Gaussian spacing. The current-meter measurements utilized a rigid frame for each bay, each holding 7 Type A ' OTT' current meters spaced log-linearly along the horizontal coordinate. The frames were mounted in the gate slots for each bay and lowered to thirteen different elevations traversing the full cross-sectional flow area. Approximately one hour was needed to complete the current-meter measurements for each wicket-gate setting. Test conditions required flowrate and head to be held constant while the velocities were measured at the different elevations in each bay.

Flowrates were continuously monitored in each bay with the ultrasonic flowmeter over the entire test sequence. Discrete flowrates for the individual bays and combined total unit

flow were determined every 4 seconds. The ultrasonic flowmeter logged all of the discrete flow and velocity data and computed average flow values corresponding to the period of each current-meter measurement cycle.

The current-meter flowrates were computed using cross-sectional bay areas taken from the plant’s original 1932 drawings. Intake surveys conducted during installation of the acoustic-path transducers showed some discrepancies between the 1932 dimensional data and the recent intake survey. In order to be consistent with the dimensions used for the current meter flowrate calculations, the ultrasonic flowrates were adjusted to identical cross-sectional flow areas. A summary of the resultant flow measurements from the two different methods is presented in Table 1.

The dimensional discrepancy was further supported by comparing the individual bay flowrates from both the acoustic flowmeter and the current meter data for the test runs. In Bays A and C, the difference between the area using the drawings and the surveyed area measurements was 1.6 %, which is consistent with the difference between the current meter and ultrasonic measurements for the flowrates in Bays A and C.

Run	1	2	3	4	5	6	7	8
Ultrasonic (CFS)	2598	3514	4748	5452	6253	7155	8317	9360
Current Meter (CFS)	2544	3468	4679	5362	6170	7066	8243	9256
% Difference	2.1	1.3	1.5	1.7	1.3	1.2	0.9	1.1

Table 1. Flowrate comparison results.

A review of the velocities on each acoustic path showed a pattern indicative of swirl and secondary flows. This pattern was made apparent in each bay by calculating the true velocity vector at each elevation in the conduit. At the top of the conduit the velocity field was one direction, and at the bottom of the penstock the direction reversed. This indicates that swirl effects may have adversely affected the current-meter readings. Bays A and C had the highest degree of swirl, while bay B had the least. Bay B had the lowest magnitudes for cross-flow components, but did not exhibit a consistent angular magnitude over the runs. These results demonstrate the need for crossed-plane flow measurements provided by the ultrasonic method.

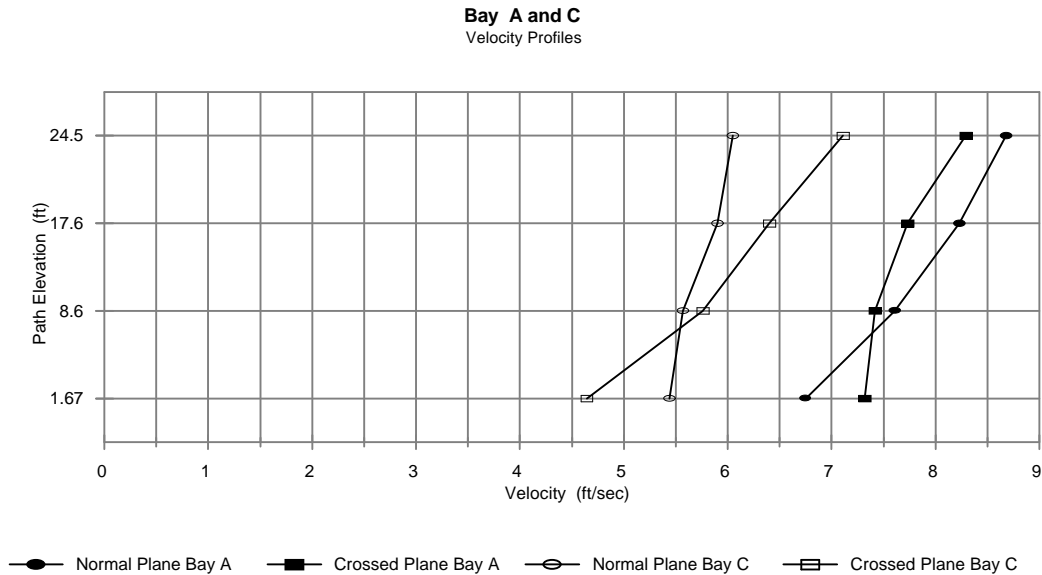

Figure 4. Typical velocity profile in 2 of 3 bays for one flowrate run.

Figure 4 is a graph of the velocity profile of Bay A and C for run 7 at Safe Harbor plotted as a function of path elevations in the conduit. This figure illustrates the need to instrument all bays with crossed planes and is typical of the entire series of test runs. The velocity profile in Bay B is omitted for clarity. These profiles show that the non-axial component of flow in Bay A is opposite in direction and different in magnitude from Bay C. This is made apparent in that the velocities on the normal plane in Bay A are for the most part larger than measured in the crossed plane. In Bay C the opposite is observed.

This figure also illustrates non-axial flow components and their potential effect on current meter accuracy near to the top and bottom of both conduits. The non-axial components of flows in both Bay A and C shows a reversal of the transverse vectors of velocity as observed from top to bottom. This reversal is usually indicative of swirl and its effect on current meters is unknown.

In summary, the multiple-path ultrasonic transit-time method can be effectively utilized for unit field efficiency testing and continuous on-line performance monitoring in low-head hydroelectric plants. The method permits flow measurements to be made without interference or obstruction to unit intake flow and can be flexibly adapted to a wide variety of intake configurations. Ultrasonic flowrate measurement accuracy has been demonstrated via intercomparison with area-velocity measurements obtained with traversing current-meter arrays.

Ultrasonic flowrate measurement techniques offer a new capability to obtain continuous high-accuracy flow data and provide much-needed hydroelectric unit performance information for use in evaluating unit upgrades and plant refurbishment programs. This will contribute significantly to better capital investment decision making and maximizing resource usage in hydroelectric power generation efficiency.

5. References

1. Gulliver, John S. and Roger E.A. Arndt, eds. 1991. *Hydropower Engineering Handbook*. McGraw-Hill, Inc., New York, New York.
2. American Society of Mechanical Engineers. 1993. *Hydraulic Turbines Performance Test Codes*. ASME PTC 18-1992 (Revision of PTC 18-1949). ASME United Engineering Center, New York, New York.
3. International Electrotechnical Commission. 1991. *International Code for the Field Acceptance Tests of Hydraulic Turbines*. International Standard IEC 41. CEI/IEC 41: 1991. Geneva, Switzerland.
4. Voight, Richard L., Jr. and John S. Gulliver. 1993. "Field Efficiency Testing: A Tool for Maximizing Performance." *Hydro Review*, Aug. 1993. pp. 108-120.
5. Levesque, Jean-Marc. 1994. "Measuring Flow with Pressure-Time, Current Meter Methods." *Hydro Review*, August, 1994. pp. 102-109.
6. Fisher, Richard K., Jr. and Gary F. Franke. 1988. "The Impact of Inlet Flow Characteristics on Low Head Hydro Projects." *Waterpower '87*. Proceedings of the International Conference on Hydropower. Portland, Oregon. pp. 1673-1680.
7. Nguyen, Thang D., James B. Nystrom, and Johannes Larsen. 1991. "Evaluation of Turbine Intake Velocity Criteria." *Waterpower '91*. Proceedings of the International Conference on Hydropower. Denver, Colorado. pp. 1706-1715.
8. Walsh, James T. 1994. "Flow Comparison Study in Low-Head Hydroplant Intakes: Ultrasonic vs. Current Meters." *Concepts for the Future*. Published in conjunction with HydroVision 94 Conference, August 17-19, 1994. pp. 41-46.